

Towards Quantum Simulation of Bound States Scattering

Matteo Turco,^{1,2,3} Gonalo M. Quinta,⁴ Joao Seixas,^{5,2,3} and Yasser Omar^{6,2,3}

¹*Instituto Superior Tecnico, Universidade de Lisboa, Portugal*

²*Physics of Information and Quantum Technologies,
Centro de Fısica e Engenharia de Materiais Avanados (CeFEMA), Portugal*

³*PQI – Portuguese Quantum Institute, Portugal*

⁴*Instituto de Telecomunicaoes, Portugal*

⁵*Departamento de Fısica, Instituto Superior Tecnico, Universidade de Lisboa, Portugal*

⁶*Departamento de Matematica, Instituto Superior Tecnico, Universidade de Lisboa, Portugal*

The last years have seen a rapid development of applications of quantum computation to quantum field theory. The first algorithms for quantum simulation of scattering have been proposed in the context of scalar and fermionic theories, requiring thousands of logical qubits. These algorithms are not suitable to simulate scattering of incoming bound states, as the initial state preparation relies typically on adiabatically transforming wavepackets of the free theory into wavepackets of the interacting theory. In this paper we present a strategy to excite wavepackets of the interacting theory directly from the vacuum of the interacting theory, allowing for preparation of states of composite particles. This is the first step towards quantum simulation of scattering of bound states. The approach is based on the Haag-Ruelle scattering theory, which provides a way to construct creation and annihilation operators of a theory in a full, nonperturbative framework. We provide a quantum algorithm requiring a number of ancillary qubits that is logarithmic in the size of the wavepackets, and with a success probability depending on the state being prepared. The gate complexity for a single iteration of the circuit is equivalent to that of a time evolution for a fixed time.

I. INTRODUCTION

The successes of last years towards implementation of quantum algorithms on real platforms are creating a growing expectation about the opportunities that quantum computation may open in different fields. One prominent area that has been particularly fruitful in providing examples of the potential advantage offered by quantum computation is high energy physics, especially for what concerns data analysis [1–8] and simulations of lattice quantum field theories [9–34]. Such theories have been exploited for many decades as a tool to numerically investigate several aspects of quantum field theory through the Euclidean path integral, which is a powerful tool in its range of applicability, but does not cover the whole class of phenomena that require real-time evolution in order to be studied. The Hamiltonian formulation in Minkowski spacetime is the natural framework for these problems, but is also hardly approachable with classical computation. In the mentioned class of phenomena, and arguably in all the theory of fundamental interactions, scattering events are of special interest, because they are almost the only probe we have to access those regimes of physics where quantum field theory is necessary. This work is about state preparation for digital quantum simulation of scattering.

The prospect of large-scale, fault-tolerant quantum computers, however far in the future, has already started to change our approach to lattice field theory with the seminal papers [9, 10] by Jordan, Lee and Preskill. There, an efficient quantum algorithm for simulation of scattering in the scalar theory ϕ^4 , requiring thousands of logical qubits, is provided and analysed. The present work will contribute in this long-term perspective by making the first step towards quantum simulation of scattering events with incoming composite particles. Preparation of bound states is an essential task in order to ultimately perform simulations of important, real-life collider events such as proton-proton scattering at the Large Hadron Collider.

Subsequent works of [9, 10] are [35–37], where the same problem is treated in different equivalent formulations such as the wavelet basis or the multi-particle decomposition of the Hilbert space. A common feature of these works is that they all rely on excited states of the associated free theory in order to prepare wavepackets of the interacting theory. As an immediate consequence, these approaches can be used only for states of the interacting theory that can be obtained smoothly (typically by an adiabatic transformation) by states of the free theory, which excludes the case of bound states.

With the framework of [9, 10] in mind, in the present work we provide a general strategy to prepare single-particle wavepackets of elementary or composite particles, with lower and upper mass gaps, on a quantum computer assuming preparation of the vacuum state of the interacting theory is available and we have access to an interpolating operator between the vacuum and the particle we want to create. The key idea is to exploit the Haag-Ruelle scattering theory, which is an alternative and complementary approach of the Lehmann-Symanzik-Zimmerman (LSZ) theory. The method requires a number of ancillary qubits that is logarithmic in the size of the wavepacket. We provide a quantum circuit with a gate complexity that is equivalent to that of a time evolution for a fixed time, and with a

certain probability of success. We provide evidence that this probability does not vanish faster than a polynomial in the relevant parameters of the simulation such as the lattice spacing. For definiteness we work here with a single scalar field, because it is an illustrative case and is directly comparable with what is available in the literature, but the idea holds, *mutatis mutandis*, with other theories as well.

State preparation is typically the most difficult step in digital quantum simulation of scattering, both technically and in terms of complexity. This work concerns only a part of it, but provides an innovative approach to the topic and clears the way to preparation of composite particles. Here we do not consider how to prepare the vacuum state. It is an interesting problem on its own and has already been addressed by other papers [38–41]. For example one may use the free vacuum preparation and the adiabatic transformation of [10], with the simplification that no backward time evolution is needed to contain premature wavepacket propagation, which we will address in the future. If one is interested only in scattering amplitudes, a simpler approach not involving quantum simulation would be [42]. However that approach works only for fixed final states and for processes with a small total number n of ingoing and outgoing particles, as the complexity scales exponentially with n .

Above we mentioned that we rely on the existence of lower and upper mass gaps, but in general we can also have bound states immersed in the continuum of multi-particle states on condition that they are protected by some symmetry. In this case our strategy is still suitable with some extra caveats. Gauge theories, as usual, require special attention too, not only for the well known issues related to quantum simulation of these theories, but also in the formulation of the Haag-Ruelle theory in presence of massless particles like photons and gluons. However, we believe that with the proper care these problems can be solved. On the other hand, it is not suited for creation of ultra-relativistic and massless particles, for which the mass gap is small or null.

The paper is divided into two main sections. In the first one we introduce very briefly the axiomatic approach to quantum field theory where the Haag-Ruelle scattering theory is developed. We list the Wightman axioms and comment some of them to introduce basic concepts of the theory. We end this section with some remarks on the applicability of the idea of this work. In the second section we describe how the Haag-Ruelle scattering theory can be used for state preparation in digital quantum simulation. We provide a quantum algorithm for particle creation from the interacting vacuum and analyse its complexity. After these two sections we give our conclusions.

II. THE HAAG-RUELLE SCATTERING THEORY

The Haag-Ruelle scattering theory is developed in the framework of axiomatic quantum field theory. The axiomatic approach provides a rigorous framework to construct a quantum field theory. It is based on a set of axioms formulated by Wightman and incorporating at the same time principles of quantum mechanics and special relativity. An important feature of this approach is that free and interacting theories are treated on equal terms. In particular interacting theories are not seen as extensions of free theories, obtained by adding interaction terms to a quadratic Hamiltonian. The difference between free and interacting theories is mainly of a pragmatical nature, because we can solve and construct explicitly free theories, but for most of the interacting theories the same is not true. For this reason it is quite uncommon to use this approach constructively. Here we assume that a theory like ϕ^4 satisfies the axioms, although a rigorous proof of this is still lacking except in one or two space dimensions [43–48]. We consider $d = D - 1$ space dimensions.

In this section we give a brief review of the axioms following essentially chapter 9 of [49]. It is convenient to divide the whole set of axioms into a few families according to their content. The first one concerns the space of states and the spectral properties of the theory:

1. **Axiom Ia** The state space \mathcal{H} of the system is a separable Hilbert space. It carries a unitary representation $U(\Lambda, x)$ (Λ an element of the Homogeneous Lorentz Group (HLG), x a spacetime coordinate vector) of the proper inhomogeneous Lorentz group (i.e., the Poincaré group). Thus, for all $|\alpha\rangle \in \mathcal{H}$, $|\alpha\rangle \rightarrow U(\Lambda, x)|\alpha\rangle$, with the $U(\Lambda, x)$ satisfying the Poincaré algebra $U(\Lambda_1, x_1)U(\Lambda_2, x_2) = U(\Lambda_1\Lambda_2, x_1 + \Lambda_1x_2)$.
2. **Axiom Ib** The infinitesimal generators P_μ of the translation subgroup $T(x) = U(\mathbb{1}, x)$ of the Poincaré group have a spectrum p_μ restricted to the forward light-cone, $p_0 \geq 0$, $p^2 \geq 0$.
3. **Axiom Ic** There is a unique state $|\Omega\rangle$, the vacuum, with the isolated eigenvalue $p_\mu = 0$ of P_μ .
4. **Axiom Id** The theory has a mass gap: the squared-mass operator $P^2 = P_\mu P^\mu$ has an isolated eigenvalue $m^2 > 0$, and the spectrum of P^2 is empty between 0 and m^2 . The subspace of \mathcal{H} corresponding to the eigenvalue m^2 carries an irreducible spin-0 representation of the HLG. These are the single-particle states of the theory. The remaining spectrum of P^2 is continuous, and begins at $(2m)^2$.

Clearly the specific form of the generators P_μ depends on the theory at hand and the generator of translations in time is the Hamiltonian, $P_0 = H$. One-particle states can be labelled according to their momentum and can be written as $|\alpha\rangle = \int d^d k g(\mathbf{k}) |\mathbf{k}\rangle$.

The next family of axioms concerns the operator content of the Hilbert space and establish what kind of fields appear in the theory:

5. **Axiom IIa** An operator-valued (tempered) distribution $\hat{\phi}(x)$ exists such that for any Schwartz test function $f(x)$ the smeared field

$$\phi_f = \int d^D x f(x) \hat{\phi}(x) \quad (1)$$

is an unbounded operator defined on a dense subset $D \subset \mathcal{H}$. Moreover, $\phi_f D \subset D$, allowing the definition of arbitrary (finite) products of smeared fields.

We recall that a Schwartz function $f(x)$ is perfectly smooth, i.e. C^∞ , and decays faster than any power as x goes to infinity.

6. **Axiom IIb** Under the unitary representation of the Poincaré group $U(\Lambda, x)$ introduced in **Axiom Ia**, the smeared fields transform as

$$U(\Lambda, x) \phi_f U^\dagger(\Lambda, x) = \phi_{f_{\Lambda, x}}, \quad f_{\Lambda, x}(y) = f(\Lambda^{-1}(y - x)). \quad (2)$$

7. **Axiom IIc** Let f_1, f_2 be Schwartz functions of compact support: thus, if f_1 vanishes outside a compact region v_1 of spacetime, and f_2 vanishes outside of the compact region v_2 , and if $x_1 - x_2$ is space-like for all $x_1 \in v_1, x_2 \in v_2$, then

$$[\phi_{f_1}, \phi_{f_2}] = 0. \quad (3)$$

8. **Axiom IId** The set of states obtained by applying arbitrary polynomials in the smeared fields ϕ_f (with all possible Schwartz functions f) to the vacuum state $|\Omega\rangle$ is dense in the Hilbert space \mathcal{H} .

In **Axiom IIa** we find an important difference with canonical quantization, namely smeared operators. In a free theory we can identify the operator-valued distribution $\hat{\phi}(x)$ with the familiar field operator. This is not a well defined operator because the state $\hat{\phi}(x)|\Omega\rangle$ has infinite norm. To avoid this problem it is necessary to introduce smearing and treat $\hat{\phi}(x)$ as a distribution. Then, by **Axiom IIb**, we can define

$$\phi_f(x) = e^{iP \cdot x} \phi_f e^{-iP \cdot x} = \int d^D y f(y - x) \hat{\phi}(y). \quad (4)$$

There are two more axioms of great importance to develop a satisfactory scattering theory:

9. **Axiom IIIa** For some one-particle state $|\alpha\rangle = \int d^d k g(\mathbf{k}) |\mathbf{k}\rangle$ with discrete eigenvalue m^2 of the squared-mass operator the smeared field $\phi_f(x)$ has a non-vanishing matrix element from this single-particle state to the vacuum, $\langle\Omega|\phi_f(x)|\alpha\rangle \neq 0$.
10. **Axiom IIIb** (asymptotic completeness) The Hilbert space \mathcal{H}_{in} (resp. \mathcal{H}_{out}) corresponding to multi-particle states of far-separated, freely moving stable particles in the far past (resp. far future) are unitarily equivalent, and may be identified with the full Hilbert space \mathcal{H} of the system.

It should be noted that **Axiom IIIb** plays a crucial role in the derivation of the LSZ reduction formula, but here is somewhat superfluous.

The joint set of eigenvalues of P_μ , labelled by p_μ has a structure made of three disconnected subsets (see figure 1). There is the vacuum subset, containing only the origin $p_\mu = 0$. Then we have the one-particle mass hyperboloid, containing all the p_μ points such that $p^2 = m^2$. Finally we have the multi-particle continuum with all the points such that $p^2 \geq 4m^2$ (in the two-particle subspace for instance, the squared mass operator gives $(p_1 + p_2)^2 = 2m^2 + 2p_1 \cdot p_2$, with $p_1 \cdot p_2 \geq m^2$).

With this in mind we define an operator $\phi_1(x)$ exactly as in (4), but with a smearing function $f_1(x)$ chosen as the Fourier transform of a function $\tilde{f}_1(p)$ with support in the region $am^2 < p^2 < bm^2$, with $0 < a < 1 < b < 4$, sandwiching the one-particle mass hyperboloid. This guarantees that the state $\phi_1(x)|\Omega\rangle$ is a one-particle (and one-particle only) state, by **Axiom IIIa**.

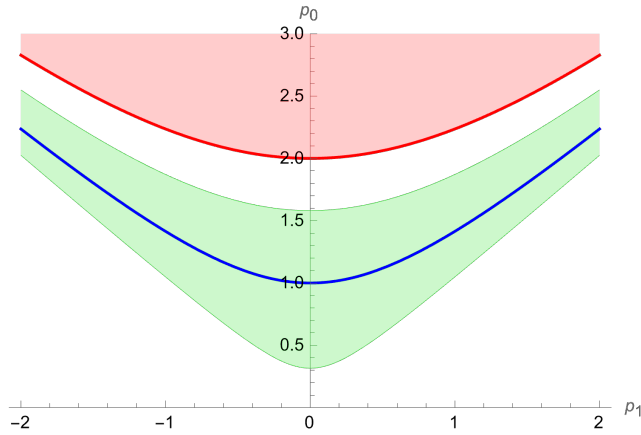

FIG. 1: Structure of the spectrum of P_μ with one space dimension. The blue line represents the one-particle mass hyperboloid, the red region is the multi-particle continuum and the green region is the region defined by $am^2 < p^2 < bm^2$.

Next consider a positive energy solution of the Klein-Gordon equation,

$$g(\tau, \mathbf{y}) = \int \frac{d^d p}{2E(\mathbf{p})} \tilde{g}(\mathbf{p}) e^{i(\mathbf{p} \cdot \mathbf{y} - E(\mathbf{p})\tau)}, \quad E(\mathbf{p}) = \sqrt{m^2 + |\mathbf{p}|^2}, \quad (5)$$

and define the operator

$$\phi_{1,g}(\tau) = -i \int d^d y \left[g(\tau, \mathbf{y}) \overleftrightarrow{\frac{\partial}{\partial \tau}} \phi_1(\tau, \mathbf{y}) \right], \quad (6)$$

where the double derivative is defined as in

$$A(\tau) \overleftrightarrow{\frac{\partial}{\partial \tau}} B(\tau) = A(\tau) \dot{B}(\tau) - \dot{A}(\tau) B(\tau). \quad (7)$$

The state $\phi_{1,g}(\tau) |\Omega\rangle$ can be shown to be independent of τ ,

$$\frac{d}{d\tau} \phi_{1,g}(\tau) |\Omega\rangle = 0. \quad (8)$$

This is no longer true in general if we consider multiple applications of such operators at the same time τ , $\phi_{1,g_1}(\tau) \cdots \phi_{1,g_2}(\tau) |\Omega\rangle$, but in this case we can count on the following theorem

Theorem 1 (Haag Asymptotic). *The time-dependent state vector*

$$|\Psi, \tau\rangle = \phi_{1,g_1}(\tau) \cdots \phi_{1,g_n}(\tau) |\Omega\rangle \quad (9)$$

converges strongly in the limit $\tau \rightarrow -\infty$ to the n -particle in-state

$$|\Psi\rangle_{in} = |g_1, g_2, \dots, g_n\rangle_{in} = \int d^d p_1 \cdots d^d p_n \tilde{\psi}_{1,g_1}(\mathbf{p}_1) \cdots \tilde{\psi}_{1,g_n}(\mathbf{p}_n) |\mathbf{p}_1 \cdots \mathbf{p}_n\rangle_{in}, \quad (10)$$

with momentum wavefunctions

$$\tilde{\psi}_{1,g_i}(\mathbf{p}_i) = (2\pi)^{d/2} \frac{\tilde{g}(\mathbf{p}_i) \tilde{f}_1(\mathbf{p}_i)}{\sqrt{2E(p_i)}}. \quad (11)$$

A remark concerning the content of this theorem may be useful at this point. The state $|\Psi\rangle_{in}$ is a Heisenberg state, which means that it is not to be taken in general as a state made of n (spatially) well-separated wavepackets, but its form depends on the time that is chosen as reference, or in other words the time at which the Heisenberg state

and the Schrödinger state coincide. We can choose a moment well before the collision between the wavepackets takes place, in which case we indeed have well-separated wavepackets, or a moment during the collision or later, in which case we can expect to have a complicated state more or less spread in space. The strong convergence of the theorem is to be taken at the same reference time, whether in the far past or not, both for $|\Psi, \tau\rangle$ and $|\Psi\rangle_{\text{in}}$. Also, the reference time should not be confused with the parameter τ appearing in the theorem.

Let us see more explicitly what stated so far, starting from the state

$$\phi_{1,g}(\tau) |\Omega\rangle = \int d^D x \psi(x; \tau) \hat{\phi}(x) |\Omega\rangle, \quad (12)$$

where, writing $x = (t, \mathbf{x})$,

$$\psi(x; \tau) = \frac{i}{2} \int d^d y \int d^d p \tilde{g}(\mathbf{p}) e^{i(\mathbf{p} \cdot \mathbf{y} - E(\mathbf{p})\tau)} \left[\frac{\dot{f}_1(t - \tau, \mathbf{x} - \mathbf{y})}{E(\mathbf{p})} - i f_1(t - \tau, \mathbf{x} - \mathbf{y}) \right]. \quad (13)$$

For our purposes it is convenient to move to the Schrödinger picture by plugging

$$\hat{\phi}(x) = e^{itH} \hat{\phi}(0, \mathbf{x}) e^{-iHt} = e^{itH} \hat{\phi}(\mathbf{x}) e^{-iHt} \quad (14)$$

into (12). If we assume, without loss of generality, $f_1(t, \mathbf{x})$ temporally peaked around $t = 0$, then $\psi(t + \tau, \mathbf{x}; \tau)$ is peaked around $t = 0$ as well. Shifting $t \rightarrow t + \tau$ we get

$$\phi_{1,g}(\tau) |\Omega\rangle = e^{iH\tau} \int d^D x \psi(t + \tau, \mathbf{x}; \tau) e^{iHt} \hat{\phi}(\mathbf{x}) |\Omega\rangle. \quad (15)$$

Looking at the expression (13), we see that, apart from the smearing due to f_1 , $\psi(t + \tau, \mathbf{x}; \tau)$ is a wavepacket moving through space as a positive energy solution of the Klein-Gordon equation with time τ . Then, for any τ , the backward time evolution operator $e^{iH\tau}$ puts the wavepacket back to its initial condition at $\tau = 0$, hence the independence of $\phi_{1,g}(\tau) |\Omega\rangle$ on τ .

Similarly, in the case of two incoming particles we can write

$$\phi_{1,g_1}(\tau) \phi_{1,g_2}(\tau) |\Omega\rangle = e^{iH\tau} \int d^D x_1 \psi_1(t_1 + \tau, \mathbf{x}_1; \tau) e^{iHt_1} \hat{\phi}(\mathbf{x}_1) e^{-iHt_1} \int d^D x_2 \psi_2(t_2 + \tau, \mathbf{x}_2; \tau) e^{iHt_2} \hat{\phi}(\mathbf{x}_2) |\Omega\rangle. \quad (16)$$

Written in this form the action of the operators $\phi_{1,g_1}(t) \phi_{1,g_2}(t)$ on the vacuum is clear: as $\tau \rightarrow -\infty$, the two wavefunctions $\psi_1(t_1 + \tau, \mathbf{x}_1; \tau)$ and $\psi_2(t_2 + \tau, \mathbf{x}_2; \tau)$ are sent back to infinity where the two operators $\hat{\phi}(\mathbf{x}_1)$ and $\hat{\phi}(\mathbf{x}_2)$ act independently from each other. Then the time evolution operator $e^{iH\tau}$ evolves the system forward making the two wavepackets approach and collide with each other, depending on the initial conditions chosen for ψ_1 and ψ_2 .

In particular we can choose $g_1(\tau, \mathbf{y}_1)$ and $g_2(\tau, \mathbf{y}_2)$ such that their wavepackets ψ_1 and ψ_2 are always well separated from each other for $\tau \leq 0$, and are on a collision course for some future time. Provided that interactions between two particles are short-ranged in the theory, we can consider the two operators $\phi_{1,g_1}(\tau)$ and $\phi_{1,g_2}(\tau)$ independent from each other and the state $\phi_{1,g_1}(\tau) \phi_{1,g_2}(\tau) |\Omega\rangle$ independent from τ for $\tau \leq 0$ with excellent precision. Thus, with a proper choice of $g_1(\tau, \mathbf{y}_1)$ and $g_2(\tau, \mathbf{y}_2)$ we can take $\tau = 0$ in (16).

We conclude this section with some remarks on the validity of the theory just described. Here we have considered for simplicity a theory with a single particle of mass m . More in general we can consider theories in which the mass-squared operator has a set of discrete eigenvalues between m^2 and $(2m)^2$. These are the bound states of the theory. Moreover we can have bound states for which the corresponding eigenvalues of P^2 fall in the multi-particle continuum on condition that they are protected by some symmetry. In this case the symmetry selects a sector of the Hilbert space and when we restrict the mass-squared operator to this sector, such eigenvalues appear as discrete points again.

The Haag Asymptotic Theorem critically depends on two assumptions:

1. existence of lower and upper mass gap for the particle we want to create in such a way that it is possible to sandwich the mass hyperboloid corresponding to such a particle;
2. we have access to an operator interpolating between the vacuum and one-particle states of the particle we want to create.

Clearly, studying these two conditions strongly depends on the theory in consideration and can be very difficult, but we can use standard techniques of lattice quantum field theory to study these properties model by model. Smearing a field operator in time can be avoided if we have at our disposal an operator that does not couple the vacuum to

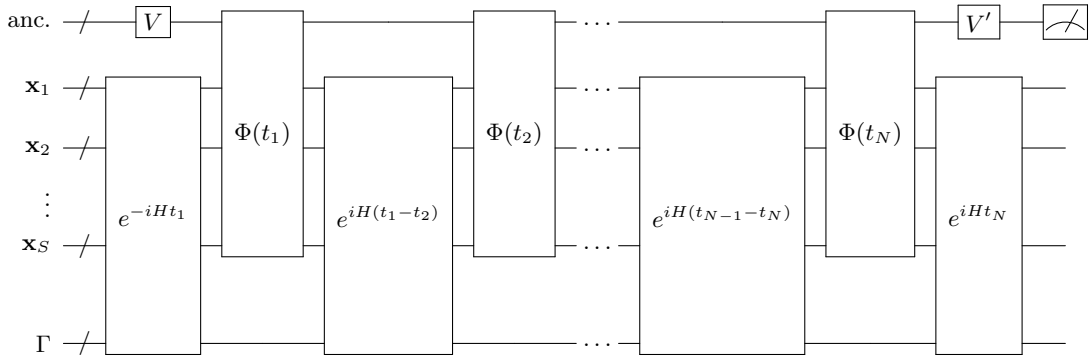

(a) **Circuit 1:** High level overview of the circuit implementing \mathcal{O} . The operators $\Phi(t_i)$ are described in the circuit below.

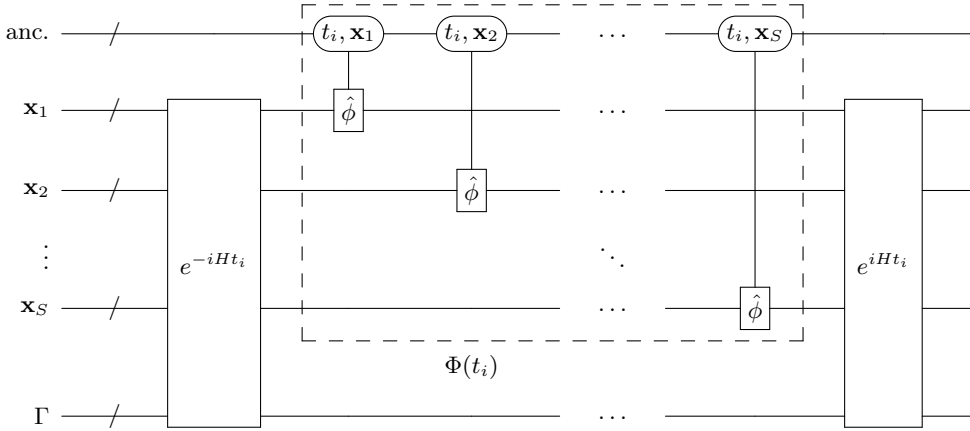

(b) **Circuit 2:** Overview of the operator implementing $\mathcal{O}(t_i)$. The symbol connecting $\hat{\phi}$ in a squared box to the rounded box containing t_i, \mathbf{x}_j represents the operator $\hat{\phi}(\mathbf{x})$ controlled on the state $|t_i, \mathbf{x}_j\rangle$.

FIG. 2: Description of the circuit implementing \mathcal{O} . The slash at the beginning of each line means that the line represents a register of qubits: anc. is the ancillary register of N_a qubits; \mathbf{x}_i is the register of k qubits dedicated to the site \mathbf{x}_i ; Γ is the set of qubits dedicated to the rest of the lattice.

multi-particle states (as it happens for free theories). For a bound state whose mass is immersed in the continuum of other particles, we also need to ensure that the interpolating operator couples only to the sector where the bound state lives. The whole framework is perfectly valid if we consider operators obtained as smeared products of the elementary fields. For example we could start with something like

$$\phi_f = \int d^D y d^D z f(y, z) \hat{\phi}_1(y) \hat{\phi}_2(z), \quad (17)$$

if the product $\hat{\phi}_1(x) \hat{\phi}_2(y)$ provides the right quantum numbers for the particle we want to create. Then everything proceeds on the same lines as above, like

$$\phi_f(x) = e^{iP \cdot x} \phi_f e^{-iP \cdot x} = \int d^D y d^D z f(y - x, z - x) \hat{\phi}_1(y) \hat{\phi}_1(z). \quad (18)$$

III. STATE PREPARATION EXPLOITING THE HAAG-RUELLE THEORY

Assuming all of this holds as an approximation on the lattice, we can write (we take $\tau = 0$ and $\psi(t, \mathbf{x}) = \psi(t, \mathbf{x}; 0)$ from now on)

$$\begin{aligned} \phi_{1,g_1}(0)\phi_{1,g_2}(0)|\Omega\rangle &= \\ &= \sum_{\mathbf{x}_1} a^d \int_{-\infty}^{+\infty} dt_1 \psi_1(t_1, \mathbf{x}_1) e^{iHt_1} \hat{\phi}(\mathbf{x}_1) e^{-iHt_1} \sum_{\mathbf{x}_2} a^d \int_{-\infty}^{+\infty} dt_2 \psi_2(t_2, \mathbf{x}_2) e^{iHt_2} \hat{\phi}(\mathbf{x}_2) |\Omega\rangle. \end{aligned} \quad (19)$$

In the following we will see how to implement the operator

$$\sum_{\mathbf{x}} a^d \int_{-\infty}^{+\infty} dt \psi(t, \mathbf{x}) e^{iHt} \hat{\phi}(\mathbf{x}) e^{-iHt} \quad (20)$$

on a quantum computer. First of all we truncate the integration over t and the summation over \mathbf{x} around the spacetime region where ψ is significantly different from zero, which, since ψ is a Schwartz function, introduces an error vanishing faster than any power as the hyper-volume of the region is increased. We label the space points in this region by $\mathbf{x}_1, \dots, \mathbf{x}_S$ and we approximate the integral with a sum over time points t_1, \dots, t_N with spacing δ_t . Thus we have

$$\mathcal{O} = \sum_{i=1}^N \sum_{j=1}^S a^d \delta_t \psi(t_i, \mathbf{x}_j) e^{iHt_i} \hat{\phi}(\mathbf{x}_j) e^{-iHt_i} = \sum_{i=1}^N \mathcal{O}(t_i). \quad (21)$$

We work in the field basis, [10, 50], where the operator $\hat{\phi}(\mathbf{x})$ is diagonal. If k qubits are dedicated to the lattice site \mathbf{x} , then $\hat{\phi}(\mathbf{x})$ is implemented by a linear combination of Z Pauli matrices,

$$\hat{\phi}(\mathbf{x}) = \frac{\phi_{\max}}{2^k - 1} \sum_{i=0}^{k-1} 2^i \sigma_{(\mathbf{x}, i)}^z. \quad (22)$$

This operator is not unitary, but can be implemented with linear combination of unitaries (LCU) [51]. Furthermore, the operator \mathcal{O} can be implemented with LCU as well, with probability of success

$$\rho = \left(\frac{\|\mathcal{O}|\Omega\rangle\|}{\alpha} \right)^2, \quad \alpha = \phi_{\max} \sum_{i=1}^N \sum_{j=1}^S a^d \delta_t |\psi(t_i, \mathbf{x}_j)|. \quad (23)$$

It is not easy to determine exactly ρ (more on this at the end of this section), but one could use, for example, the techniques described in [52] to find numerical estimates for it. Then, one would have to repeat state preparation $O(1/\rho)$ times in order to get the desired initial state, or, alternatively, one could apply amplitude amplification [52] to obtain a quadratic speed-up at the expense of a larger circuit depth.

Circuit description We want to give a high-level description of a circuit implementing \mathcal{O} so we will focus only on the dependence on the lattice sites and the time to keep the discussion concise. We take a register of $N_a = \lceil \log(kNS) \rceil$ ancillary qubits and we label the computational basis as $|t_i, \mathbf{x}_j\rangle$, with $i = 1, \dots, N$ and $j = 1, \dots, S$.

We define operators V_ψ and V'_ψ such that

$$V_\psi |0\rangle^{\otimes N_a} = \frac{1}{\sqrt{\|\psi\|_1}} \sum_{i=1}^N \sum_{j=1}^S \sqrt{a^d \delta_t \psi(t_i, \mathbf{x}_j)} |t_i, \mathbf{x}_j\rangle, \quad (24)$$

$$V'^\dagger_\psi |0\rangle^{\otimes N_a} = \frac{1}{\sqrt{\|\psi\|_1}} \sum_{i=1}^N \sum_{j=1}^S \left(\sqrt{a^d \delta_t \psi(t_i, \mathbf{x}_j)} \right)^* |t_i, \mathbf{x}_j\rangle. \quad (25)$$

Then the circuits in figure 2 implement the operator \mathcal{O} written in (21) up to a normalization factor and when the state $|0\rangle^{\otimes N_a}$ is obtained by measuring the ancillary register. In general we have $t_1 < 0$, $t_N > 0$ and $t_i - t_{i+1} = -\delta_t$, therefore the sequence of time evolution operators appearing in **Circuit 1** consists of a backward evolution for time $|t_1|$, followed by N steps forward, each one of time δ_t for a total of $t_N - t_1$, and by a final backward evolution for time t_N . In **Circuit 2** we notice that controlling only each $\hat{\phi}$ is equivalent to controlling $e^{-iHt_i} \hat{\phi} e^{iHt_i}$ because $e^{-iHt_i} e^{iHt_i} = \mathbb{1}$.

Complexity We will show that the complexity of **Circuit 1** is dominated by the sequence of time evolutions. We do not want to discuss here how to implement the time evolution, as this is not in the scope of this work.

The sequence of operators $\Phi(t_1), \dots, \Phi(t_N)$ requires $O(SN)$ gates, as well as the operators V and V' that basically provide generic state preparation on N_a qubits, and we have $S < \mathcal{V}$. We can estimate the error introduced by discretizing the integral over t , and hence how large N needs to be, in the following way. We take $t_0 = t_1 - \delta_t/2$ and $T = t_N - t_1 + \delta_t$. Then we split the integral from t_0 to $t_0 + T$ into N integrals in the following way:

$$\begin{aligned} \int_{t_0}^{t_0+T} \psi(t, \mathbf{x}) e^{iHt} \hat{\phi}(\mathbf{x}) e^{-iHt} dt &= \sum_{i=1}^N \int_{t_i - \frac{\delta_t}{2}}^{t_i + \frac{\delta_t}{2}} \psi(t, \mathbf{x}) e^{iHt} \hat{\phi}(\mathbf{x}) e^{-iHt} dt \\ &= \sum_{i=1}^N \int_{-\frac{\delta_t}{2}}^{\frac{\delta_t}{2}} \psi(t_i + t, \mathbf{x}) e^{iHt_i} e^{iHt} \hat{\phi}(\mathbf{x}) e^{-iHt} e^{-iHt_i} dt, \end{aligned} \quad (26)$$

where from the first to the second line we have shifted the integration variable, $t \rightarrow t + t_i$. We expand $e^{iHt} \hat{\phi}(\mathbf{x}) e^{-iHt}$ using the well known formula

$$e^A B e^{-A} = B + [A, B] + \frac{1}{2} [A, [A, B]] + \dots \quad (27)$$

and $\psi(t_i + t, \mathbf{x})$ using the Taylor expansion around $t = 0$ up to order t^2 . Odd orders in t do not contribute because the integration domain is symmetric around zero. The leading order gives us exactly the operators appearing in (21). We use the spectral norm of the next to leading order to estimate the error due to discretization and we apply the triangular inequality:

$$\begin{aligned} \epsilon &= \frac{\delta_t^3}{24} \left\| \sum_{i=1}^N e^{iHt_i} \left(\ddot{\psi}(t_i, \mathbf{x}) \hat{\phi}(\mathbf{x}) + 2i\dot{\psi}(t_i, \mathbf{x}) [H, \hat{\phi}(\mathbf{x})] - \psi(t_i, \mathbf{x}) [H, [H, \hat{\phi}(\mathbf{x})]] \right) e^{-iHt_i} \right\| \\ &\leq \frac{\delta_t^2}{24} \left(\sum_{i=1}^N \delta_t |\ddot{\psi}(t_i, \mathbf{x})| \|\hat{\phi}(\mathbf{x})\| + 2 \sum_{i=1}^N \delta_t |\dot{\psi}(t_i, \mathbf{x})| \|[H, \hat{\phi}(\mathbf{x})]\| + \sum_{i=1}^N \delta_t |\psi(t_i, \mathbf{x})| \|[H, [H, \hat{\phi}(\mathbf{x})]]\| \right). \end{aligned} \quad (28)$$

The dominant contribution is given by the term with $[H, [H, \hat{\phi}(\mathbf{x})]]$ and the quantity

$$\sum_{i=1}^N \delta_t |\psi(t_i, \mathbf{x})| \quad (29)$$

is approximately a constant independent of the lattice and the precision. Finally, given that $T = \delta_t N$, we have

$$N = O\left(\frac{T}{\sqrt{\epsilon}} \sqrt{\|[H, [H, \hat{\phi}(\mathbf{x})]]\|}\right). \quad (30)$$

If we use a first-order Suzuki-Trotter formula to implement the time evolution, we need [53]

$$N_{\text{ST}} = O\left(\frac{T^2}{\epsilon} \|[H_\phi, H_\pi]\| \right) \quad (31)$$

Trotter steps to keep the error below ϵ . As the reader may check by looking at expressions (32) and (33), the commutator $[H_\phi, H_\pi]$ scales with the total size of the lattice, as it involves a summation over all the sites, while $[H, [H, \hat{\phi}(\mathbf{x})]]$ involves only a few neighbours of \mathbf{x} . Thus, N_{ST} clearly dominates over N even if we consider higher order product formulae. This shows that the complexity is determined by the time evolution.

For the ϕ^4 theory we have

$$[H, [H, \hat{\phi}(\mathbf{x})]] = \frac{1}{a^2} \sum_{i=1}^d \left[2\hat{\phi}(\mathbf{x}) - \hat{\phi}(\mathbf{x} + \hat{\mathbf{r}}_i) - \hat{\phi}(\mathbf{x} - \hat{\mathbf{r}}_i) \right] + m_0^2 \hat{\phi}(\mathbf{x}) + \frac{\lambda_0}{3!} \hat{\phi}(\mathbf{x})^3, \quad (32)$$

$$\begin{aligned} [H_\phi, H_\pi] &= i \sum_{\mathbf{x}} a^d \left[\frac{1}{a^2} \sum_{j=1}^d \left(\hat{\phi}(\mathbf{x}) \hat{\pi}(\mathbf{x}) + \hat{\phi}(\mathbf{x} + \hat{\mathbf{r}}_j) \hat{\pi}(\mathbf{x} + \hat{\mathbf{r}}_j) - \hat{\phi}(\mathbf{x} + \hat{\mathbf{r}}_j) \hat{\pi}(\mathbf{x}) - \hat{\phi}(\mathbf{x}) \hat{\pi}(\mathbf{x} + \hat{\mathbf{r}}_j) - \frac{i}{a^d} \right) \right. \\ &\quad \left. + \frac{m_0^2}{2} \left(2\hat{\phi}(\mathbf{x}) \hat{\pi}(\mathbf{x}) - \frac{i}{a^d} \right) + \frac{\lambda_0}{12} \left(2\hat{\phi}^3(\mathbf{x}) \hat{\pi}(\mathbf{x}) - \frac{3i}{a^d} \hat{\phi}(\mathbf{x})^2 \right) \right]. \end{aligned} \quad (33)$$

On the success probability Here we want to provide some intuition on what to expect from the probability ρ . We can write the vacuum state in the basis of $\hat{\phi}(\mathbf{x})$ as

$$|\Omega\rangle = \sum_{\phi_1, \dots, \phi_{\mathcal{V}}} \Omega(\phi_1, \dots, \phi_{\mathcal{V}}) |\phi_1 \dots \phi_{\mathcal{V}}\rangle, \quad (34)$$

where $1, \dots, \mathcal{V}$ is some labelling of the lattice sites such that $1, \dots, S$ are the sites on the support of ψ . Then, our target state is

$$\begin{aligned} \mathcal{O}|\Omega\rangle &= \sum_{i=1}^N \sum_{j=1}^S a^d \delta_t \psi(t_i, \mathbf{x}_j) e^{it_i H} \hat{\phi}(\mathbf{x}_j) |\Omega\rangle \\ &= \sum_{\{\phi\}} \sum_{i=1}^N \delta_t \Psi_{t_i}(\phi_1, \dots, \phi_S) \Omega(\phi_1, \dots, \phi_S) e^{it_i H} |\phi_1 \dots \phi_{\mathcal{V}}\rangle, \end{aligned} \quad (35)$$

where

$$\Psi_{t_i}(\phi_1, \dots, \phi_S) = \sum_{j=1}^S a^d \psi(t_i, \mathbf{x}_j) \phi_j. \quad (36)$$

Introducing $|\Psi_{t_k} \Omega\rangle = \sum_{\{\phi\}} \Psi_{t_k}(\{\phi\}) \Omega(\{\phi\}) |\{\phi\}\rangle$, the squared norm can be written as

$$\|\mathcal{O}|\Omega\rangle\|^2 = \sum_{i=1}^N \delta_t^2 \langle \Psi_{t_i} \Omega | \Psi_{t_i} \Omega \rangle + \sum_{i \neq j} \delta_t^2 \operatorname{Re} \langle \Psi_{t_i} \Omega | e^{iH(t_i - t_j)} | \Psi_{t_j} \Omega \rangle. \quad (37)$$

In the second summation, the matrix elements with small $|t_i - t_j|$ should not be far from $\|\Psi_{t_i} \Omega\|^2$. When $|t_i - t_j|$ starts growing, negative contributions should start to appear, and cancellations between matrix elements start to occur. However, terms with large $|t_i - t_j|$ are suppressed by the fast decay of ψ , so the second summation should be positive. Thus, we are led to think that the first summation gives the dominant contribution, that is, written more explicitly,

$$\|\mathcal{O}|\Omega\rangle\|^2 \gtrsim \sum_{i=1}^N \sum_{\{\phi\}} \delta_t^2 |\Psi_{t_i}(\phi_1, \dots, \phi_S) \Omega(\phi_1, \dots, \phi_{\mathcal{V}})|^2. \quad (38)$$

The region identified by $\Psi_{t_i}(\phi_1, \dots, \phi_S) = 0$ is a hyperplane crossing the origin in the hyperspace of the variables $\phi_1, \dots, \phi_{\mathcal{V}}$.

A basic example from the harmonic oscillator in one dimension should help to gain some insight. The ground state of the harmonic oscillator is a normalized Gaussian

$$\omega(\tilde{\phi}) = \left(\frac{1}{\pi \tilde{s}^2} \right)^{\frac{1}{4}} \exp\left(-\frac{\tilde{\phi}^2}{2\tilde{s}^2} \right). \quad (39)$$

Then, the state $\tilde{\phi} \omega(\tilde{\phi})$ has squared norm

$$\int_{-\infty}^{+\infty} d\tilde{\phi} \tilde{\phi}^2 \omega^2(\tilde{\phi}) = \frac{\tilde{s}^2}{2}, \quad (40)$$

and $\tilde{\phi} \omega(\tilde{\phi})/\tilde{s}$ has squared norm $O(1)$.

Going back to our case, let s be the linear size of $\Omega(\phi_1, \dots, \phi_{\mathcal{V}})$ in the hyperspace of $\phi_1, \dots, \phi_{\mathcal{V}}$. Then it is quite reasonable to say that $\|\mathcal{O}|\Omega\rangle\|/s = O(1)$ and thus

$$\rho = \left(\frac{\|\mathcal{O}|\Omega\rangle\|/s}{\alpha/s} \right)^2 = O\left(\left(\frac{s}{\phi_{\max}} \right)^2 \right). \quad (41)$$

In the case of a single harmonic oscillator with energy \tilde{E} , it is enough to take $(\tilde{s}/\tilde{\phi}_{\max})^2 = O(1/\tilde{E})$. In the case of the ϕ^4 theory on the lattice, it is harder to determine the scaling of s/ϕ_{\max} . However, in [9, 10], a rough polynomial estimate for ϕ_{\max} is given, which is probably overly pessimistic, and overall we can conclude that ρ does not vanish faster than a polynomial.

IV. CONCLUSIONS

In this paper we provide a quantum algorithm to create single-particle wavepackets of a lattice quantum field theory starting from the vacuum state. The method we propose is quite general and the idea is independent of details of the model. For example it works equally well for free and interacting theories. The key aspect of our strategy is that it is suitable for preparation of composite particles, which is an important novelty in the context of quantum simulation of relativistic scattering. To our knowledge this is the first work on state preparation of bound states for quantum simulation of scattering.

The work is based on the Haag-Ruelle scattering theory in the framework of axiomatic quantum field theory, which is ideal for quantum simulation as it is developed in the operator formalism. In this respect this work also shows the potential importance that the axiomatic approach might have on quantum computation applied to quantum field theory, as both fields are suited to nonperturbative investigations from first principles.

This work alone is not enough to complete state preparation of scattering, but it decomposes the problem into more approachable ones. On one hand, efficient techniques to prepare the vacuum state are required. On the other, one has to find interpolating operators with the right properties for a given particle in a given theory, and needs to know the size of the corresponding lower and upper mass gaps. On the first front much work has already been done in the context of quantum computation, while for the second front standard techniques of Euclidean lattice field theory are available. As a next step, the approach of this work needs to be specialized case by case. Also, we need to investigate how gauge invariance and presence of massless particles affect this approach.

ACKNOWLEDGMENTS

We thank Duarte Magano and Miguel Murça for their introduction to the techniques of linear combination of unitaries exploited in this work. We also thank Pieralberto Marchetti and Marco Matone for discussions and help concerning the Haag-Ruelle scattering theory. Furthermore, we thank the support from FCT – Fundação para a Ciência e a Tecnologia (Portugal), namely through project UIDB/04540/2020, as well as from projects QuantHEP and HQCC supported by the EU QuantERA ERA-NET Cofund in Quantum Technologies and by FCT (QuantERA/0001/2019 and QuantERA/004/2021, respectively), and from the EU Quantum Flagship project EuRyQa (101070144).

-
- [1] T. Felser, M. Trenti, L. Sestini, A. Gianelle, D. Zuliani, D. Lucchesi, and S. Montangero, Quantum-inspired machine learning on high-energy physics data (2021), arXiv:2004.13747 [stat.ML].
 - [2] D. Pires, Y. Omar, and J. Seixas, Adiabatic quantum algorithm for multijet clustering in high energy physics (2020), arXiv:2012.14514 [hep-ex].
 - [3] D. Pires, P. Bargassa, J. Seixas, and Y. Omar, A digital quantum algorithm for jet clustering in high-energy physics (2021), arXiv:2101.05618 [physics.data-an].
 - [4] D. Magano, A. Kumar, M. Kālis, A. Locāns, A. Glos, S. Pratapsi, G. Quinta, M. Dimitrijevs, A. Rivošs, P. Bargassa, J. Seixas, A. Ambainis, and Y. Omar, Quantum speedup for track reconstruction in particle accelerators, *Physical Review D* **105**, 10.1103/physrevd.105.076012 (2022), arXiv:2104.11583 [quant-ph].
 - [5] P. Bargassa, T. Cabos, A. C. O. Choi, T. Hessel, and S. Cavinato, Quantum algorithm for the classification of supersymmetric top quark events, *Physical Review D* **104**, 10.1103/physrevd.104.096004 (2021), arXiv:2106.00051 [quant-ph].
 - [6] A. Delgado, K. E. Hamilton, P. Date, J.-R. Vlimant, D. Magano, Y. Omar, P. Bargassa, A. Francis, A. Gianelle, L. Sestini, D. Lucchesi, D. Zuliani, D. Nicotra, J. de Vries, D. Dibenedetto, M. L. Martinez, E. Rodrigues, C. V. Sierra, S. Vallecorsa, J. Thaler, C. Bravo-Prieto, su Yeon Chang, J. Lazar, C. A. Argüelles, and J. J. M. de Lejarza, Quantum computing for data analysis in high energy physics (2022), arXiv:2203.08805 [physics.data-an].
 - [7] J. Schuhmacher, L. Boggia, V. Belis, E. Puljak, M. Grossi, M. Pierini, S. Vallecorsa, F. Tacchino, P. Barkoutsos, and I. Tavernelli, Unravelling physics beyond the standard model with classical and quantum anomaly detection (2023), arXiv:2301.10787 [hep-ex].
 - [8] A. Crippa, L. Funcke, T. Hartung, B. Heinemann, K. Jansen, A. Kropf, S. Kühn, F. Meloni, D. Spataro, C. Tüysüz, and Y. C. Yap, Quantum algorithms for charged particle track reconstruction in the LUXE experiment (2023), arXiv:2304.01690 [quant-ph].
 - [9] S. P. Jordan, K. S. M. Lee, and J. Preskill, Quantum algorithms for quantum field theories, *Science* **336**, 1130 (2012), arXiv:1111.3633 [quant-ph].
 - [10] S. P. Jordan, K. S. M. Lee, and J. Preskill, Quantum computation of scattering in scalar quantum field theories, *Quantum Info. Comput.* **14**, 1014–1080 (2014), arXiv:1112.4833 [hep-th].

- [11] S. P. Jordan, K. S. M. Lee, and J. Preskill, Quantum algorithms for fermionic quantum field theories (2014), arXiv:1404.7115 [hep-th].
- [12] J. Preskill, Simulating quantum field theory with a quantum computer (2018), arXiv:1811.10085 [hep-lat].
- [13] A. Avkhadiev, P. E. Shanahan, and R. D. Young, Accelerating lattice quantum field theory calculations via interpolator optimization using noisy intermediate-scale quantum computing, *Physical Review Letters* **124**, 10.1103/physrevlett.124.080501 (2020), arXiv:1908.04194 [hep-lat].
- [14] A. Avkhadiev, P. E. Shanahan, and R. D. Young, Strategies for quantum-optimized construction of interpolating operators in classical simulations of lattice quantum field theories, *Physical Review D* **107**, 10.1103/physrevd.107.054507 (2023), arXiv:2209.01209 [hep-lat].
- [15] N. Klco, M. J. Savage, and J. R. Stryker, SU(2) non-Abelian gauge field theory in one dimension on digital quantum computers, *Physical Review D* **101**, 10.1103/physrevd.101.074512 (2020), arXiv:1908.06935 [quant-ph].
- [16] M. Kreshchuk, W. M. Kirby, G. Goldstein, H. Beauchemin, and P. J. Love, Quantum simulation of quantum field theory in the light-front formulation, *Physical Review A* **105**, 10.1103/physreva.105.032418 (2022), arXiv:2002.04016 [quant-ph].
- [17] W. Qian, R. Basili, S. Pal, G. Luecke, and J. P. Vary, Solving hadron structures using the basis light-front quantization approach on quantum computers, *Physical Review Research* **4**, 10.1103/physrevresearch.4.043193 (2022), arXiv:2112.01927 [quant-ph].
- [18] C. W. Bauer, B. Nachman, and M. Freytsis, Simulating collider physics on quantum computers using effective field theories, *Physical Review Letters* **127**, 10.1103/physrevlett.127.212001 (2021), arXiv:2102.05044 [hep-ph].
- [19] Y. Y. Atas, J. Zhang, R. Lewis, A. Jahanpour, J. F. Haase, and C. A. Muschik, SU(2) hadrons on a quantum computer via a variational approach, *Nature Communications* **12**, 10.1038/s41467-021-26825-4 (2021), arXiv:2102.08920 [quant-ph].
- [20] A. Kan and Y. Nam, Lattice quantum chromodynamics and electrodynamics on a universal quantum computer (2022), arXiv:2107.12769 [quant-ph].
- [21] C. W. Bauer and D. M. Grabowska, Efficient representation for simulating U(1) gauge theories on digital quantum computers at all values of the coupling, *Phys. Rev. D* **107**, L031503 (2023), arXiv:2111.08015 [hep-ph].
- [22] A. M. Czajka, Z.-B. Kang, H. Ma, and F. Zhao, Quantum simulation of chiral phase transitions, *Journal of High Energy Physics* **2022**, 10.1007/jhep08(2022)209 (2022), arXiv:2112.03944 [hep-ph].
- [23] Y. Y. Atas, J. F. Haase, J. Zhang, V. Wei, S. M. L. Pfaendler, R. Lewis, and C. A. Muschik, Simulating one-dimensional quantum chromodynamics on a quantum computer: Real-time evolutions of tetra- and pentaquarks (2023), arXiv:2207.03473 [quant-ph].
- [24] R. C. Farrell, I. A. Chernyshev, S. J. M. Powell, N. A. Zemlevskiy, M. Illa, and M. J. Savage, Preparations for quantum simulations of quantum chromodynamics in 1 + 1 dimensions. I. Axial gauge, *Physical Review D* **107**, 10.1103/physrevd.107.054512 (2023), arXiv:2207.01731 [quant-ph].
- [25] R. C. Farrell, I. A. Chernyshev, S. J. M. Powell, N. A. Zemlevskiy, M. Illa, and M. J. Savage, Preparations for quantum simulations of quantum chromodynamics in 1 + 1 dimensions. II. Single-baryon β -decay in real time, *Physical Review D* **107**, 10.1103/physrevd.107.054513 (2023), arXiv:2209.10781 [quant-ph].
- [26] Z. Davoudi, N. Mueller, and C. Powers, Toward quantum computing phase diagrams of gauge theories with thermal pure quantum states (2022), arXiv:2208.13112 [hep-lat].
- [27] Z. Davoudi, N. Mueller, and C. Powers, Toward exploring phase diagrams of gauge theories on quantum computers with thermal pure quantum states (2022), arXiv:2212.11388 [hep-lat].
- [28] D. M. Grabowska, C. Kane, B. Nachman, and C. W. Bauer, Overcoming exponential scaling with system size in Trotter-Suzuki implementations of constrained Hamiltonians: 2+1 U(1) lattice gauge theories (2023), arXiv:2208.03333 [quant-ph].
- [29] C. Kane, D. M. Grabowska, B. Nachman, and C. W. Bauer, Efficient quantum implementation of 2+1 U(1) lattice gauge theories with Gauss law constraints (2022), arXiv:2211.10497 [quant-ph].
- [30] C. F. Kane, D. M. Grabowska, B. Nachman, and C. W. Bauer, Overcoming exponential volume scaling in quantum simulations of lattice gauge theories (2022), arXiv:2212.04619 [hep-lat].
- [31] H. Lamm, S. Lawrence, and Y. Y. and (NuQS), Parton physics on a quantum computer, *Physical Review Research* **2**, 10.1103/physrevresearch.2.013272 (2020), arXiv:1908.10439 [hep-lat].
- [32] B. Nachman, D. Provasoli, W. A. de Jong, and C. W. Bauer, Quantum algorithm for high energy physics simulations, *Physical Review Letters* **126**, 10.1103/physrevlett.126.062001 (2021), arXiv:1904.03196 [hep-ph].
- [33] G. Gustafson, S. Prestel, M. Spannowsky, and S. Williams, Collider events on a quantum computer, *Journal of High Energy Physics* **2022**, 10.1007/jhep11(2022)035 (2022), arXiv:2207.10694 [hep-ph].
- [34] L. Funcke, T. Hartung, K. Jansen, and S. Kühn, Review on quantum computing for lattice field theory (2023), arXiv:2302.00467 [hep-lat].
- [35] G. K. Brennen, P. Rohde, B. C. Sanders, and S. Singh, Multiscale quantum simulation of quantum field theory using wavelets, *Physical Review A* **92**, 10.1103/physreva.92.032315 (2015), arXiv:1412.0750 [quant-ph].
- [36] M. Bagherimehrab, Y. R. Sanders, D. W. Berry, G. K. Brennen, and B. C. Sanders, Nearly optimal quantum algorithm for generating the ground state of a free quantum field theory, *PRX Quantum* **3**, 10.1103/prxquantum.3.020364 (2022), arXiv:2110.05708 [quant-ph].
- [37] J. Barata, N. Mueller, A. Tarasov, and R. Venugopalan, Single-particle digitization strategy for quantum computation of a ϕ^4 scalar field theory, *Physical Review A* **103**, 10.1103/physreva.103.042410 (2021), arXiv:2012.00020 [hep-th].
- [38] N. Klco and M. J. Savage, Systematically localizable operators for quantum simulations of quantum field theories, *Physical Review A* **102**, 10.1103/physreva.102.012619 (2020), arXiv:1912.03577 [quant-ph].
- [39] A. C. Y. Li, A. Macridin, S. Mrenna, and P. Spentzouris, Simulating scalar field theories on quantum computers with limited resources, *Physical Review A* **107**, 10.1103/physreva.107.032603 (2023), arXiv:2210.07985 [quant-ph].

- [40] D. Paulson, L. Dellantonio, J. F. Haase, A. Celi, A. Kan, A. Jena, C. Kokail, R. van Bijnen, K. Jansen, P. Zoller, and C. A. Muschik, Simulating 2D effects in lattice gauge theories on a quantum computer, *PRX Quantum* **2**, 10.1103/prxquantum.2.030334 (2021), arXiv:2008.09252 [quant-ph].
- [41] A. N. Ciavarella and I. A. Chernyshev, Preparation of the SU(3) lattice Yang-Mills vacuum with variational quantum methods, *Physical Review D* **105**, 10.1103/physrevd.105.074504 (2022), arXiv:2112.09083 [quant-ph].
- [42] T. Li, W. K. Lai, E. Wang, and H. Xing, Scattering amplitude from quantum computing with reduction formula (2023), arXiv:2301.04179 [hep-ph].
- [43] J. Glimm and A. Jaffe, A $\lambda\phi^4$ quantum field theory without cutoffs. I, *Phys. Rev.* **176**, 1945 (1968).
- [44] J. Glimm and A. Jaffe, The $\lambda(\phi^4)_2$ quantum field theory without cutoffs: II. The field operators and the approximate vacuum, *Annals of Mathematics* **91**, 362 (1970).
- [45] J. Glimm and A. Jaffe, The $\lambda(\phi^4)_2$ quantum field theory without cutoffs: III. The physical vacuum, *Acta Mathematica* **125**, 203 (1970).
- [46] J. Glimm and A. Jaffe, The $\lambda\phi^4$ Quantum Field Theory without Cutoffs. IV. Perturbations of the Hamiltonian, *Journal of Mathematical Physics* **13**, 1568 (2003).
- [47] J. Glimm and A. Jaffe, Positivity of the ϕ^4_3 Hamiltonian, *Fortschritte der Physik* **21**, 327 (1973).
- [48] J. Glimm, A. Jaffe, and T. Spencer, The Wightman axioms and particle structure in the $P(\phi)_2$ quantum field model, *Annals of Mathematics* **100**, 585 (1974).
- [49] A. Duncan, *The Conceptual Framework of Quantum Field Theory* (Oxford University Press, 2012).
- [50] N. Klco and M. J. Savage, Digitization of scalar fields for quantum computing, *Physical Review A* **99**, 10.1103/physreva.99.052335 (2019), arXiv:1808.10378 [quant-ph].
- [51] A. M. Childs, R. Kothari, and R. D. Somma, Quantum algorithm for systems of linear equations with exponentially improved dependence on precision, *SIAM Journal on Computing* **46**, 1920 (2017), arXiv:1511.02306 [quant-ph].
- [52] G. Brassard, P. Høyer, M. Mosca, and A. Tapp, Quantum amplitude amplification and estimation, in *Quantum computation and information (Washington, DC, 2000)*, *Contemp. Math.*, Vol. 305 (Amer. Math. Soc., Providence, RI, 2002) pp. 53–74, arXiv:quant-ph/0005055.
- [53] A. M. Childs, Y. Su, M. C. Tran, N. Wiebe, and S. Zhu, Theory of Trotter error with commutator scaling, *Physical Review X* **11**, 10.1103/physrevx.11.011020 (2021), arXiv:1912.08854 [quant-ph].